

# Compact rooftop air conditioner AUSTRAL B & AUSTRAL Combi



The AUSTRAL B (Air conditioning only) and AUSTRAL Combi (Air conditioning and heating) compact air conditioners are easily adapted to all types of cabs in which the inside space is insufficient to contain integrated equipment. Fitting the AUSTRAL B and AUSTRAL Combi on the back of the rooftop eliminates the risk of protruding beyond the top of the cab.

Condenser, evaporator, filter drier, pressure switches and control devices are all contained in the one unit. This unit is to be connected to the compressor through 2 hoses.

The AUSTRAL B and AUSTRAL Combi are equipped with a combined dust and active carbon filtration system.

The AUSTRAL B and AUSTRAL Combi are available in white or black and in 12 or 24 V.

## CONTROL PANEL



**AUSTRAL B**



**AUSTRAL Combi**

## TECHNICAL SPECIFICATIONS

AUTRAL	B	Combi
<b>A/C performance</b>	4,8 KW IMACA Standard 200	4,8 KW IMACA Standard 200
<b>Heating Performance</b>		3Kw
<b>Maximum air flow</b>	420 m <sup>3</sup> /h	420 m <sup>3</sup> /h
<b>Electrical power</b>	380 W	380 W
<b>Weight</b>	36 Kg	36 Kg
<b>Outside air</b>	10 %	10 %
<b>Air filtration</b>	Dust and active carbon EU5-F5	
<b>Compressor to be used</b>	Sanden SD 7H15 / 5H14	

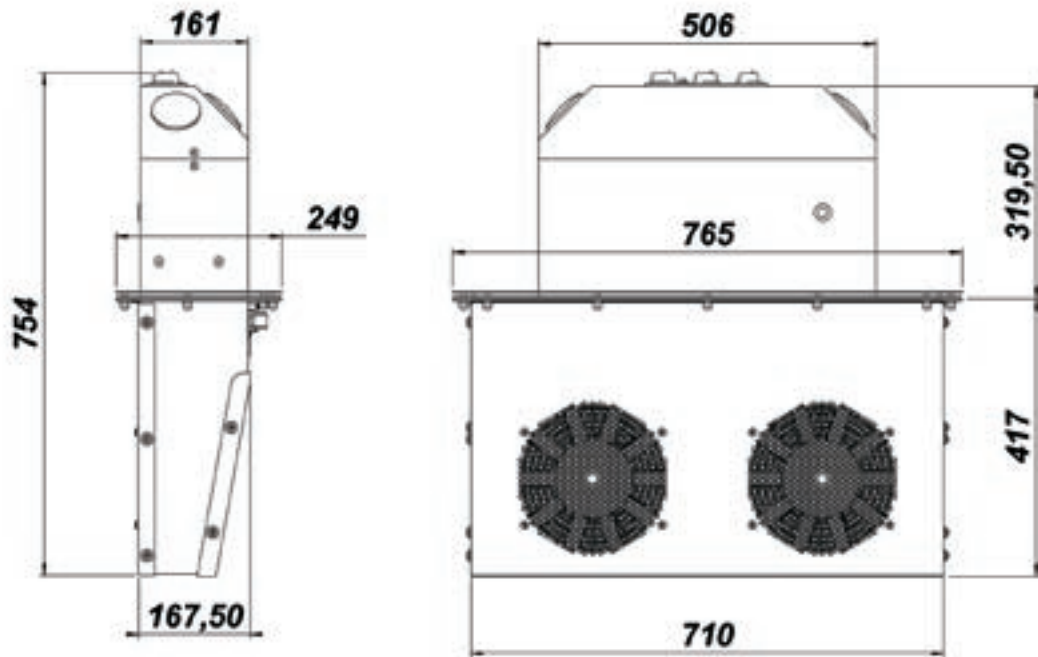

**PART NUMBERS**

P/N		Voltage		Colour	
AUSTRAL B	AUSTRAL combi	12V	24V	White	Black
320A13	320A14	•		•	
320A17	320A18		•	•	
320A15	320A16	•			•
320A19	320A20		•		•